

# 梅花式联轴器 ◀ 螺钉固定型/螺钉夹紧型(铝合金)

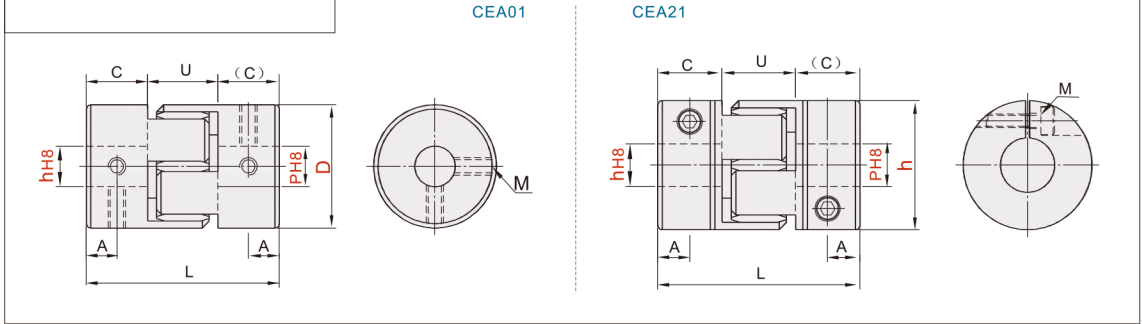

代码	类型	材质	表面处理	附件
		主体膜片	主体	
CEA01	螺钉固定型	铝合金	阳极氧化	紧定螺钉
CEA21	螺钉夹紧型			内六角圆柱头螺钉

- ① 顺时针和逆时针回转特性一样;
- ② 补偿径向、角向、轴向偏差。



型号	代码	D	h-p
CEA01	14	3 4 5 6 6.35 7	
	20	4 5 6 6.35 7 8 9 9.525 10	
	25	5 6 6.35 7 8 9 9.525 10 11 12	
	30	5 6 6.35 7 8 9 9.525 10 11 12 12.7 13 14 15	
	35	8 9 9.525 10 11 12 12.7 13 14 15 16 17	
	40	8 9 9.525 10 11 12 12.7 13 14 15 16 17 18 19 20 22	
	40L	8 9 9.525 10 11 12 12.7 13 14 15 16 17 18 19 20 22	
	55	12 12.7 13 14 15 16 17 18 19 20 22 24 25 28 30	
	65	14 15 16 17 18 19 20 22 24 25 28 30 32 35 36 38	
80	19 20 22 24 25 28 30 32 35 36 38 40 42 45		

型号	代码	D	h-p
CEA21	14	3 4 5 6 6.35 7	
	20	4 5 6 6.35 7 8 9 9.525 10	
	25	5 6 6.35 7 8 9 9.525 10 11 12	
	30	5 6 6.35 7 8 9 9.525 10 11 12 12.7 13 14 15	
	35	8 9 9.525 10 11 12 12.7 13 14 15 16 17	
	40	8 9 9.525 10 11 12 12.7 13 14 15 16 17 18 19 20 22	
	40L	8 9 9.525 10 11 12 12.7 13 14 15 16 17 18 19 20 22	
	55	12 12.7 13 14 15 16 17 18 19 20 22 24 25 28 30	
	65	14 15 16 17 18 19 20 22 24 25 28 30 32 35 36 38	
80	19 20 22 24 25 28 30 32 35 36 38 40 42 45		

## ■ 尺寸性能表

代码	D	L	C	U	A	M	锁紧扭矩 (N·m)	额定扭矩 (N·m)	最大扭矩 (N·m)	最高转速 (r/pm)	惯性力矩 (kg·m <sup>2</sup> )	静态扭转刚性 (N·m/rad)	径向弹性常 数(N/mm)	径向偏差 (mm)	角向偏差 (°)	轴向偏差 (mm)	重量 (g)	
CEA01	14	22	7.5	7	3.8	M3	0.7	2	4	10000	$1.98 \times 10^{-7}$	20	368	0.1	1	±0.6	6	
	20	30	10.3	9	5.2	M4	1.7	4.8	9.6		$1.09 \times 10^{-6}$	42	388			±0.8	18	
	25	34	11.5	11	5.8	M4	1.7	9.5	19		$4.26 \times 10^{-6}$	95	518			±0.9	32	
	30	35	11.7	11.6	5.9	M4	1.7	12	24		$6.19 \times 10^{-6}$	132	630			±1	47	
	35	50	18	14	9	M5	4	15	30		$2.56 \times 10^{-5}$	950	1030			±1.1	90	
	40	55	20	15	10	M5	4	16.5	33		$3.34 \times 10^{-5}$	1250	1370			±1.2	123	
	40L	66	25.5	15	12.8	M5	4	16.5	33		$4.01 \times 10^{-5}$	1500	1650			±1.2	150	
	55	78	30.5	17	15.3	M6	7	58	116		7000	$1.63 \times 10^{-4}$	1940			1310	±1.4	346
	65	90	36	18	18	M8	15	155	310		6000	$3.69 \times 10^{-4}$	3010			1360	±1.5	510
80	114	46	22	23	M8	15	315	630	5000	$1.04 \times 10^{-3}$	5820	1660	±1.8	1010				
CEA21	14	22	7.5	7	3.8	M2.5	1	2	4	10000	$1.98 \times 10^{-7}$	20	368	0.1	1	±0.6	6	
	20	30	10.3	9	5.2	M3	1.5	4.8	9.6		$1.09 \times 10^{-6}$	42	388			±0.8	18	
	25	34	11.5	11	5.8	M4	3.4	9.5	19		$4.26 \times 10^{-6}$	95	518			±0.9	32	
	30	35	11.7	11.6	5.9	M4	3.4	12	24		$6.19 \times 10^{-6}$	132	630			±1	47	
	35	50	18	14	9	M5	7	15	30		$2.56 \times 10^{-5}$	950	1030			±1.1	90	
	40	55	20	15	10	M5	7	16.5	33		$3.34 \times 10^{-5}$	1250	1370			±1.2	123	
	40L	66	25.5	15	12.8	M5	7	16.5	33		$4.01 \times 10^{-5}$	1500	1650			±1.2	152	
	55	78	30.5	17	15.3	M6	14	58	116		7000	$1.63 \times 10^{-4}$	1940			1310	±1.4	346
	65	90	36	18	18	M8	30	155	310		6000	$3.69 \times 10^{-4}$	3010			1360	±1.5	532
80	114	46	22	23	M8	30	315	630	5000	$1.04 \times 10^{-3}$	5820	1660	±1.8	1000				



请按图示订货

### ■ CEA01-D20-h5-p8

型号		h-p
代码	D	
CEA01	20	4 5 6 6.35 7 8 9 9.525 10



交期Delivery

3天 发货

○本产品发货时间不含周日