

凸轮套

SJQ21



SJQ23



SJQ22



SJQ24



类型	本体	螺母
SJQ21	SCM440	不锈钢
SJQ22	无电解镀锌	/
SJQ23	SCS24	不锈钢
SJQ24	(SUS630 相近)	/

SJQ21/22

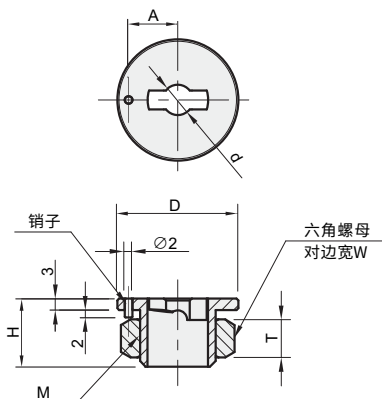

SJQ23/24

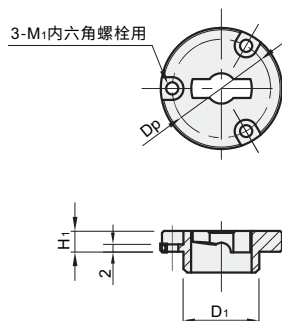

型号	适用板厚度	D	H	d +0.06Y +0.04	A (±0.1)	M	T	W	D ₁ -0.04 -0.08	H ₁	M ₁	D _p	质量 (g)	适用 转拇指型锁紧器		
SJQ21-0525-N	薄板用	6~10	25	16	5	10.5	M14×1.5 (细牙)	8	22	/	/	/	/	40	SJQ01	0525-10
SJQ23-0525-N-SUS															SJQ02	0834-14
SJQ21-0834-N		6~12	32	18	8	3	M20×1.5 (细牙)	10	30	/	/	/	/	55	SJQ04	0834-20
SJQ23-0834-N-SUS	嵌入用	超过10	25	9	5	/	/	/	14	4.5	M2	21	20	20	SJQ05	0525-10
SJQ22-0525-B															SJQ11	0834-14
SJQ24-0525-B-SUS		超过12	32	11	8	/	/	/	20	5.5	M3	26	35	SJQ12	0834-20	
SJQ22-0834-B		SJQ24-0834-B-SUS														

转拇指型锁紧器本体和凸轮套的安装位置关系

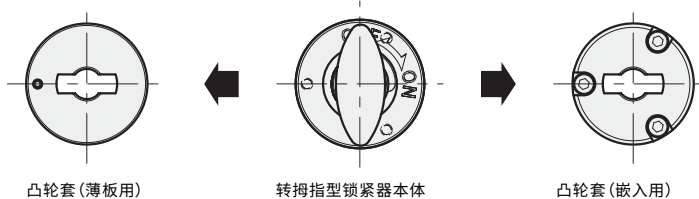

凸轮套 (薄板用)

转拇指型锁紧器本体

凸轮套 (嵌入用)



请按图示订货

■ SJQ21-0525-N

规格		适用板厚度	
SJQ21	0525-N	薄板用	6~10



交期Delivery

5天 发货

○本产品发货时间不含周日



www.vipdo.cn 400-098-1117

工厂自动化零件一站式采购平台

汇集国内外知名品牌，让采购更便捷，让设计更高效！