

ZAL系列减速机

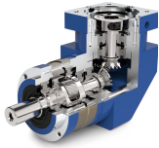

- ①采用斜齿齿轮传动，经渗碳淬火处理，齿向齿廓修形处理，确保运行低噪音、平稳；承载能力较直齿提高20%；
- ②整体式输出轴，行星轮两端轴承支撑，实现高精度、强度；
- ③伞齿轮采用磨齿工艺精度可达6级，确保运行低噪音、平稳；
- ④回程间隙小，精密型单级可以做到5arcmin以内。

代码	型号
ZDX06	ZAL70
	ZAL90
	ZAL120
	ZAL155

ZAL70-L1

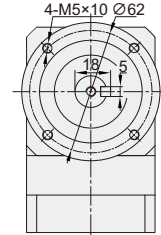
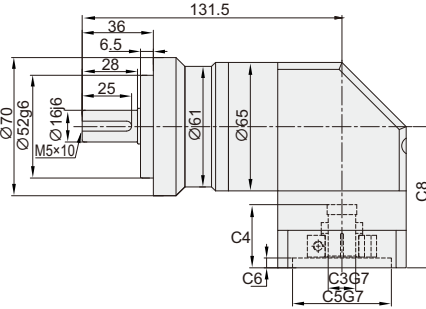
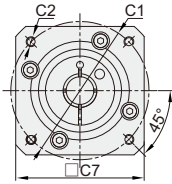

ZAL70-L2

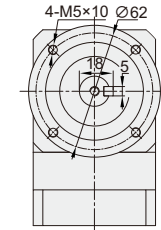
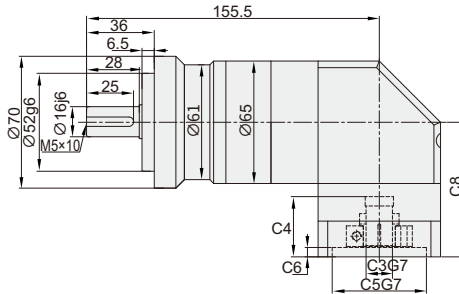
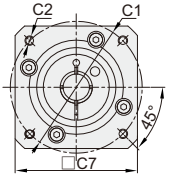

ZAL90-L1

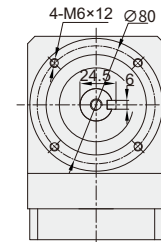
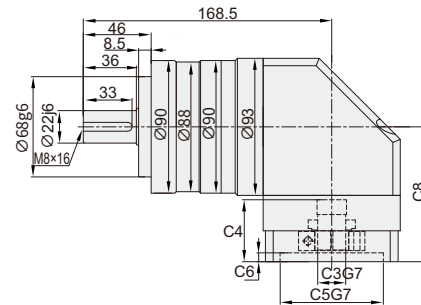
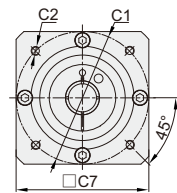

ZAL90-L2

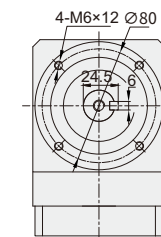
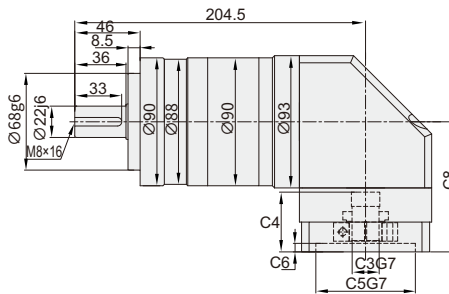
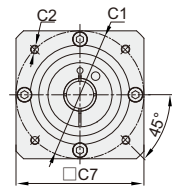

ZAL系列减速机

ZAL120-L1

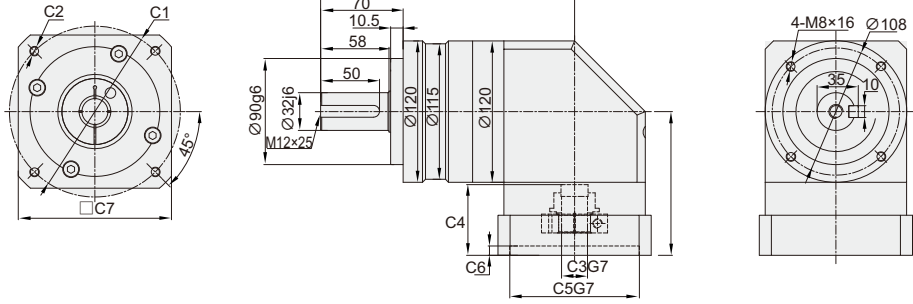

ZAL120-L2

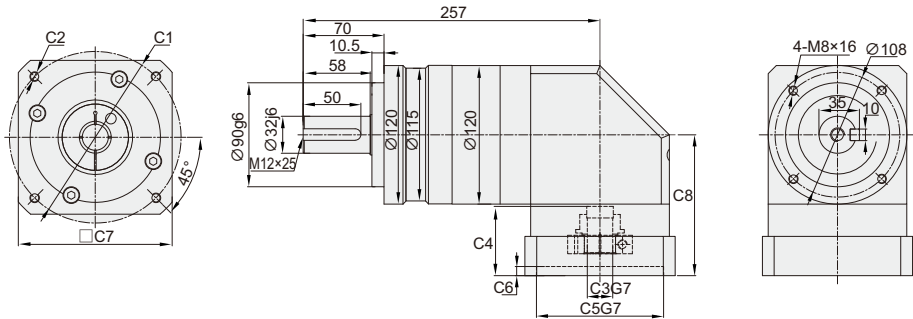

ZAL155-L1

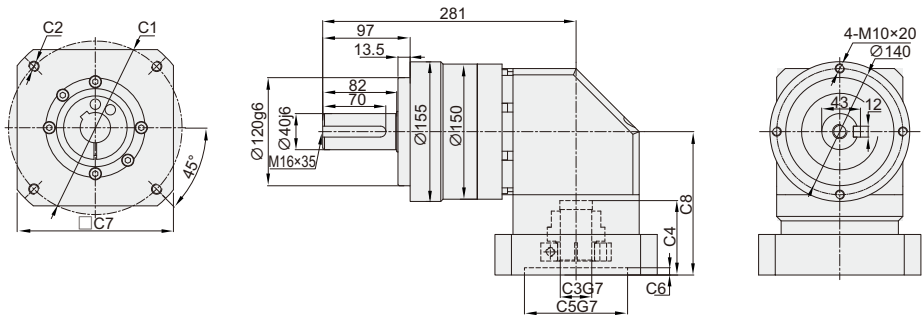

ZAL155-L2

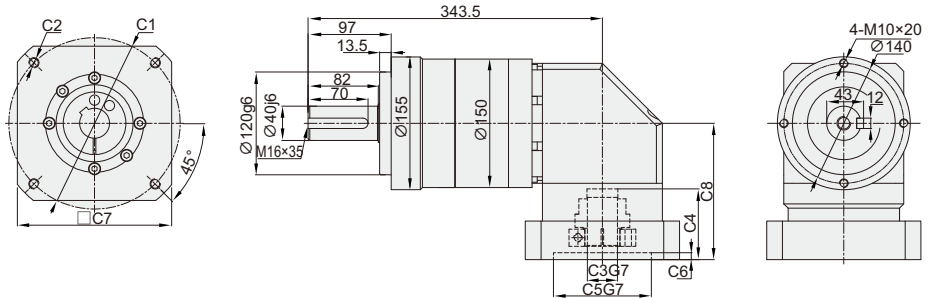

ZAL系列减速机

尺寸	电机尺寸	C1	C2	C3	C4	C5	C6	C7	C8
ZAL70-L1	M1	φ70	4-M4	φ14	32	φ50	5	65	71.5
	M2	φ70	4-M5	φ14	32	φ50	5	65	71.5
ZAL70-L2	M1	φ70	4-M4	φ14	32	φ50	5	65	71.5
	M2	φ70	4-M5	φ14	32	φ50	5	65	71.5

尺寸	电机尺寸	C1	C2	C3	C4	C5	C6	C7	C8
ZAL90-L1	M1	φ98.5	4-M5	φ14	42	φ73	6	90	91.5
	M2	φ90	4-M5	φ19	42	φ70	6	90	91.5
	M3	φ90	4-M6	φ19	42	φ70	6	90	91.5
	M4	φ115	4-M8	φ19	54	φ95	8	110	103.5
	M5	φ130	4-M8	φ19	54	φ95	8	110	103.5
ZAL90-L2	M1	φ98.5	4-M5	φ14	42	φ73	6	90	91.5
	M2	φ90	4-M5	φ19	42	φ70	6	90	91.5
	M3	φ90	4-M6	φ19	42	φ70	6	90	91.5
	M4	φ115	4-M8	φ19	54	φ95	8	110	103.5
	M5	φ130	4-M8	φ19	54	φ95	8	110	103.5

尺寸	电机尺寸	C1	C2	C3	C4	C5	C6	C7	C8
ZAL120-L1	M1	φ115	4-M8	φ22	57.0	φ95	8	130	119
	M2	φ115	4-M8	φ24	57.0	φ95	8	130	119
	M3	φ145	4-M8	φ22	60.0	φ110	8	130	122
	M4	φ145	4-M8	φ24	60.0	φ110	8	130	122
ZAL120-L2	M1	φ115	4-M8	φ22	57.0	φ95	8	130	119
	M2	φ115	4-M8	φ24	57.0	φ95	8	130	119
	M3	φ145	4-M8	φ22	60.0	φ110	8	130	122
	M4	φ145	4-M8	φ24	60.0	φ110	8	130	122

尺寸	电机尺寸	C1	C2	C3	C4	C5	C6	C7	C8
ZAL155-L1	M1	φ145	4-M8	φ22	72.5	φ110	8	130	149
	M2	φ145	4-M8	φ24	72.5	φ110	8	130	149
	M3	φ200	4-M12	φ35	82.5	φ114.3	8	180	159
ZAL155-L2	M1	φ145	4-M8	φ22	72.5	φ110	8	130	149
	M2	φ145	4-M8	φ22	72.5	φ110	8	130	149
	M3	φ200	4-M12	φ35	82.5	φ114.3	8	180	159

注：1. L1为1段速比，L2为2段速比。2.如需其他电机安装尺寸可与我司联系。



www.vipdo.cn

400-098-1117

工厂自动化零件一站式采购平台

汇集国内外知名品牌，让采购更便捷，让设计更高效！

ZAL系列减速机

型号	单位	ZAL070	ZAL090	ZAL120	ZAL155	减速比	阶段	
额定输出扭矩	N.m	35	100	230	450	3	1	
		45	110	270	580	4		
		44	105	255	540	5		
		40	100	180	390	7		
		22	50	120	230	10	2	
		35	100	230	450	15		
		45	110	270	580	16		
		45	110	270	580	20		
		44	105	255	540	25		
		45	110	270	580	28		
		35	100	230	450	30		
		44	105	255	540	35		
		45	110	270	580	40		
		44	105	255	540	50		
		40	100	180	390	70		
		22	50	120	230	100		
故障停滞扭矩	N.m	3倍额定输出扭矩						
额定输入转速	rpm	3000	3000	3000	2000			
额定输入转速	rpm	6000	6000	6000	4000			
最大径向力 ¹	N	920	1400	3000	5800			
最大轴向力 ¹	N	630	600	2500	4500			
效率	%	单一[95%]			双倍[93%]			
平均寿命	h	20000						
重量(大概)	kg	2.1	5.6	11	24		1	
		2.6	6.6	14	30		2	
转动惯量	kgcm ²	0.39	2.45	6.7	27	3	1	
		0.34	2.22	5.4	22	4		
		0.32	2.13	5	21	5		
		0.31	2.06	4.6	19	7		
		0.3	2.02	4.4	19	10		
		0.11	0.6	0.8	15	15		
		0.12	0.65	0.9	15	16	2	
		0.11	0.59	0.8	14	20		
		0.11	0.59	0.8	14	25		
		0.12	0.64	0.8	15	28		
		0.10	0.51	0.7	13	30		
		0.11	0.59	0.8	14	35		
		0.10	0.51	0.7	13	40		
		0.10	0.51	0.7	13	50		
		0.10	0.51	0.7	13	70		
		0.10	0.51	0.7	13	100		
回程间隙	arcmin	≤7	≤7	≤7	≤10		L1-P1	
		≤10	≤10	≤10	≤12		L1-P2	
		≤10	≤10	≤10	≤12		L2-P1	
		≤12	≤12	≤12	≤14		L2-P2	
抗扭刚性	N.m/arc min	7	14	25	50			
噪音	dB	65	65	68	70			
润滑		合成油脂润滑						
防护等级		Ip65						

注：1.1输出转速为100rpm时，作用于输出轴中心位置。2. L1为1段速比，L2为2段速比。3.如需其他电机安装尺寸可与我司联系。



请按图示订货

■ ZDX06-ZAL70-L1-10-S2-P2-M1-T

代码	减速机系列名称	减速比	输出方式	精度	电机尺寸	可选
ZDX06	ZAL70-L1	10	S1:无输出轴键 S2:附带输出轴键	P1 P2	M1 M2	T:输入端 开键槽



交期Delivery

3天 发货

○本产品发货时间不含周日



www.vipdo.cn



400-098-1117

工厂自动化零件一站式采购平台

汇集国内外知名品牌，让采购更便捷，让设计更高效！